

Vox®

Tel 800 668 9318
Tel 416 298 5700
Fax 416 298 9535
mail@nienkamper.com
www.nienkamper.com

OPEN OFFICE™ INSTALLATION GUIDE



ALLEN KEYS

Small 4 mm
For hex socket assembly, to join rails together.
For installing bases to rails.
For installing mounting plate to top.

Large 5 mm
Used to join rail together



FLAT HEAD HEX SOCKET ASSEMBLY

4/5mm - 5/8" x 1/4" - 20 and threaded collar
Joins rails together.



FLAT HEAD HEX SOCKET BOLT

4 mm - 9/16" x 1/4" - 20
Joins large table support brackets to rails.



FLAT HEAD HEX SOCKET BOLT

4 mm - 1" x 1/4" - 20
Joins mounting plate to top.
Joins bases to table top.



TIGHT JOINT FASTENERS

3 piece assembly plus 1 tightening rod.



WOODEN SPLINE

1/8" x 7/8" x (24" - varies)
Inserts into the edge of multi piece tops
and divider panels for alignment.



MOUNTING PLATE

1/4" x 3" x 4"
Fixes rail to top.

ASSEMBLING SUPPORT RAILS

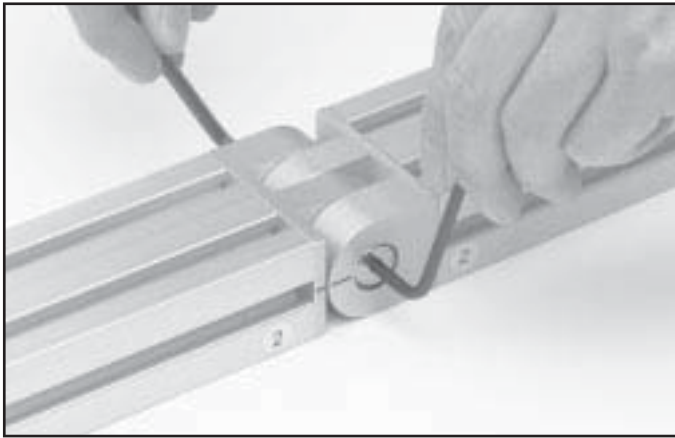

1

- Position and assemble the rail connecting joints as shown.
- Matching joints are coded by number (circular labels).
- Required hardware: 2" x 1/4"-20 flat head socket assembly.
- Tighten joint, aligning marks as shown.

POSITIONING SUPPORT RAILS

2

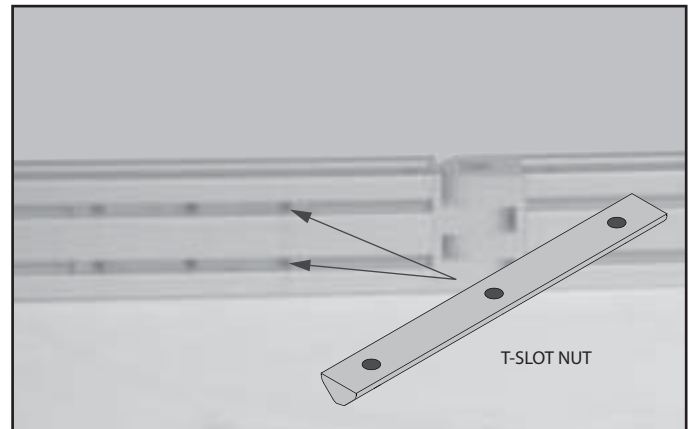

- Align both sets of rails on the ground so that pre installed t-slot nuts are facing inward.

PREPARING LEGS FOR ATTACHMENT TO RAIL

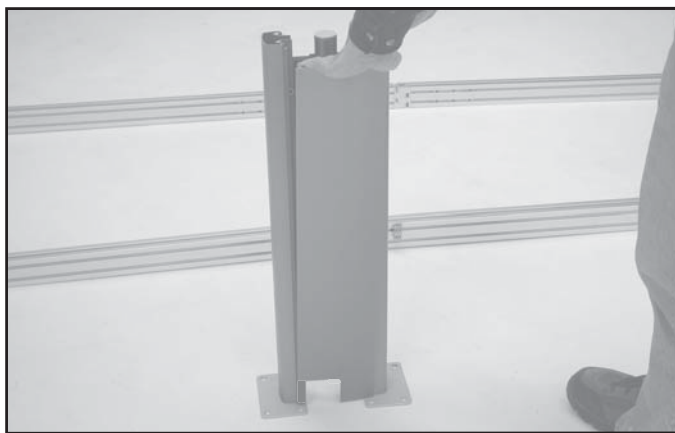

3

- Remove the exterior panels from the legs.
- The legs with two mounting plates(as shown) are used on the main tops.
- Set aside the legs with a single mounting plate. They will be used on the returns.

FASTENING LEG TO RAIL

4

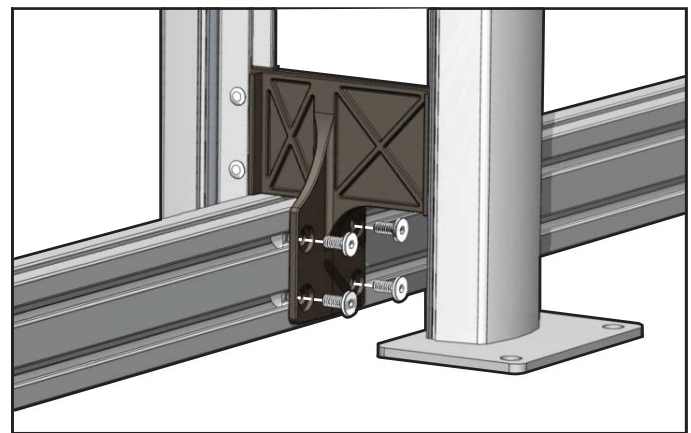

- Place the base upside down over the rail.
- Align holes in the upper base support bracket with threaded holes in the t-slot nuts.
The rail and the base should both be flat to the ground.
- Fasten the base to the t-slot nuts with 9/16" x 1/4"-20 flat head hex socket bolt (4 per base).

JOINING LEG/RAIL ASSEMBLIES

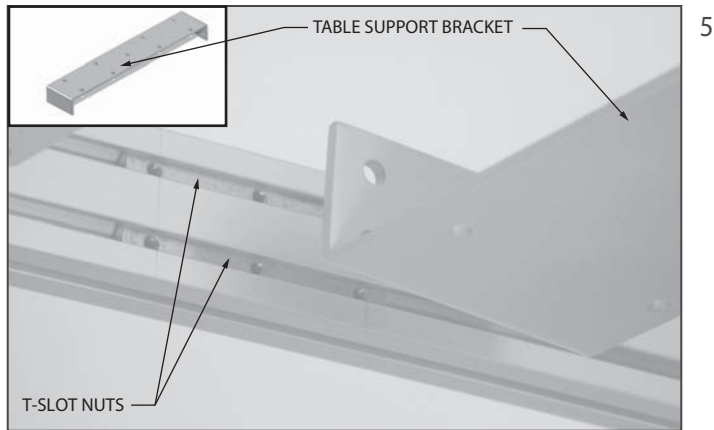

- Align the support bracket with the t-slot nuts which are fixed on the rail.
- Join both sets of rails to the support-bracket.

FASTENING SUPPORT BRACKET TO RAIL



- Attach the support bracket to the rail using 9/16" x 1/4"-20 flat head hex socket bolts (8 per bracket).

ROTATING BASE STRUCTURE

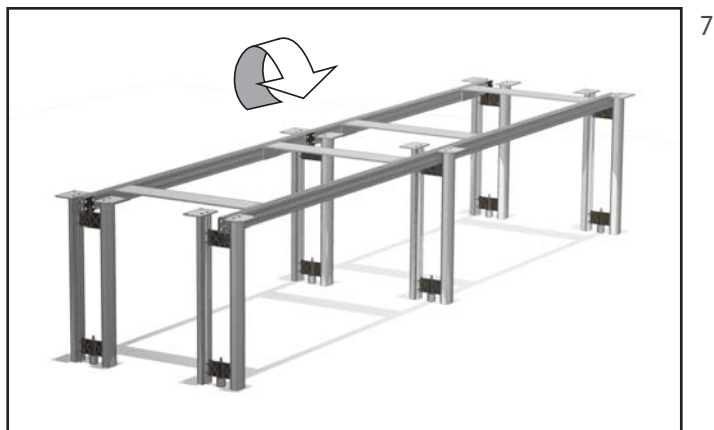

- With one person at each end, rotate entire base and rail structure so levelers are on floor.

Do not rest all the weight on one corner while rotating the base assembly.

INSTALLING PENCIL STOP



- Place the work top on a clean surface bottom side up.
- Position the L-shape pencil stop onto the routed groove at the back of the worksurface.
- The holes in the pencil stop should be facing the bottom of the top.
- Justify the angled end of the pencil stop with the edge of the top.
- Secure L-extrusion to the top with #6 x 5/8" screws.
- If a glass divider is used, a space will be left at the seam to allow for a glass divider to pass through.

POSITION TOPS FOR ATTACHMENT

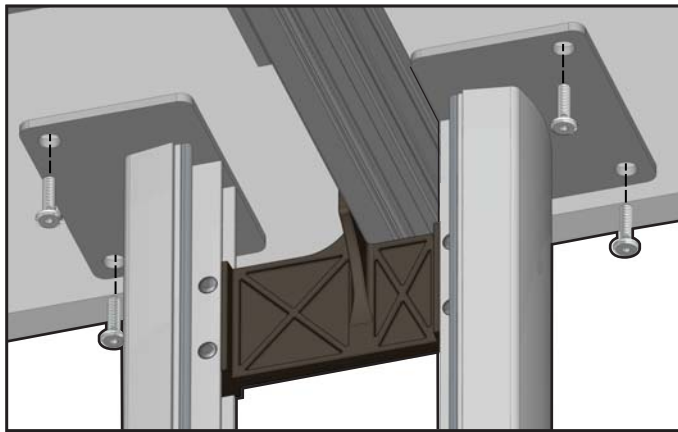

9

- Locate the top section onto the base assembly and loosely secure with 1" x 1/4 - 20 flat head hex socket bolts (x2 per base plate).

The station will need to be leveled before all of the bolts can be completely tightened.

JOINING MULTI PIECE TOPS

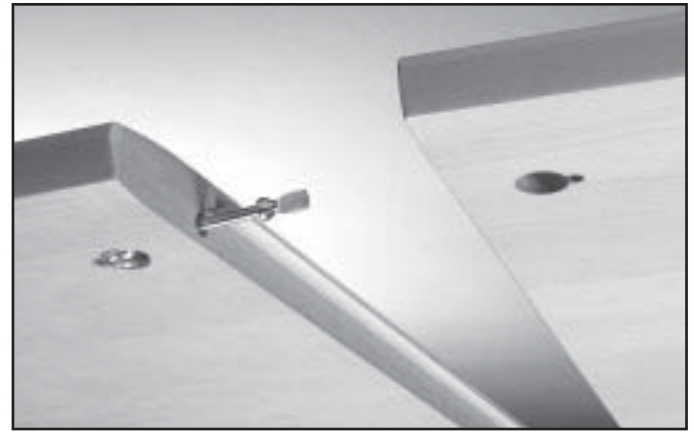

10

- Position top seams together and insert wooden spline into the groove in one seam.
- Insert ball fitting of the tight joint bolt and start the thread.

LEVELING

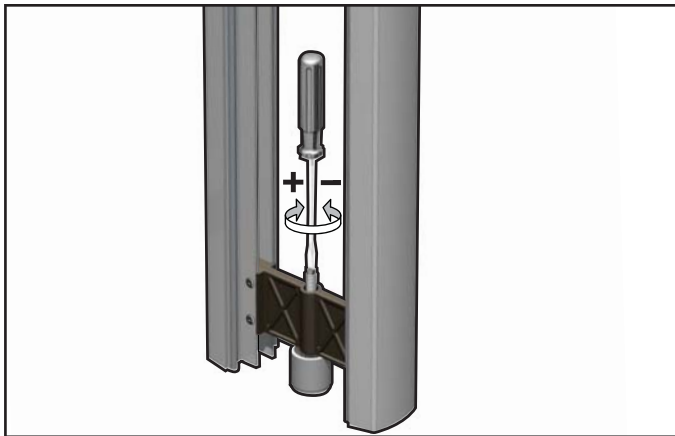

11

- Level the station by rotating the leveler foot stem located in each base with either a flat head screwdriver or drill with suitable bit.

GLASS DIVIDER INSTALLATION

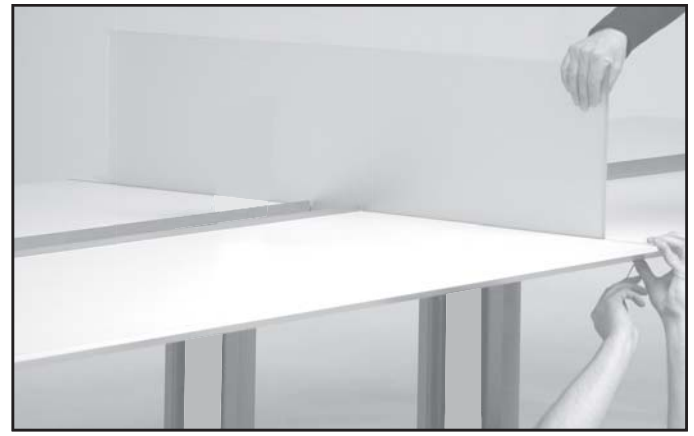

12

When a glass divider is supplied

- Place the 1/2" glass panel in the slot between the two tops.
- If the panel does not slide in easy, loosen the bolts on the center bases.
- One person will need to hold the glass panel in place as the other person tightens the tight joint fastener, as shown in figure 14.
- Tighten bolts on the bases.

GLASS DIVIDER INSTALLATION

TOP TO BASE ATTACHMENT

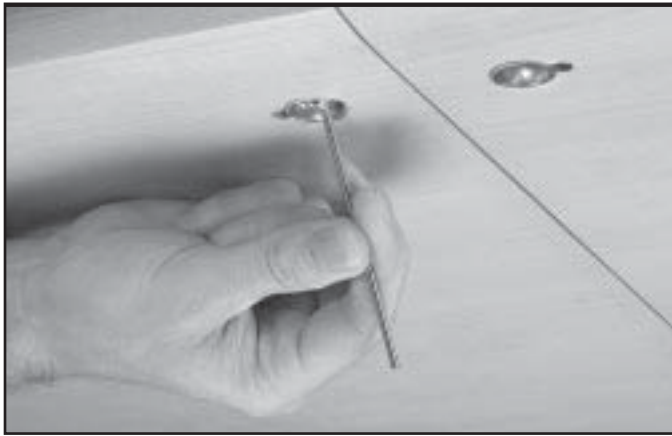

13

- While ensuring tops are aligned tighten tight joint fasteners.



14

- Insert the mounting plate into the top groove of the rail.
- Slide the plate to align threaded inserts of top with the holes in the mounting plate.

INSTALLING THE DIVIDER

POSITIONING THE DIVIDER

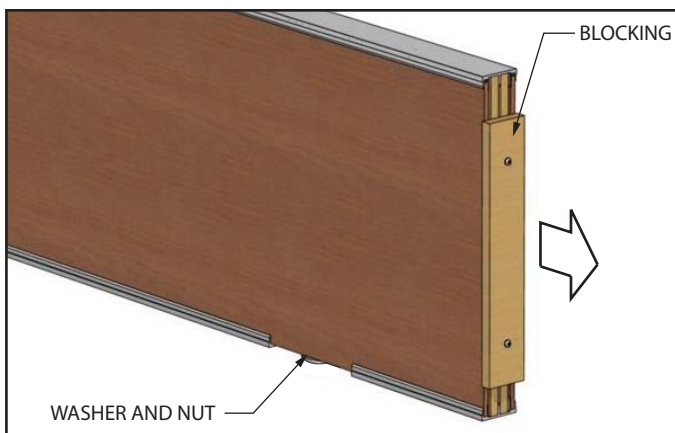

15

- Blocking is used for shipping purposes only. Remove the blocking by loosening the wood screws.
- Remove the washer and 3/8" nut from the bottom of the divider. These will be used later for attaching the divider to the table support bracket.

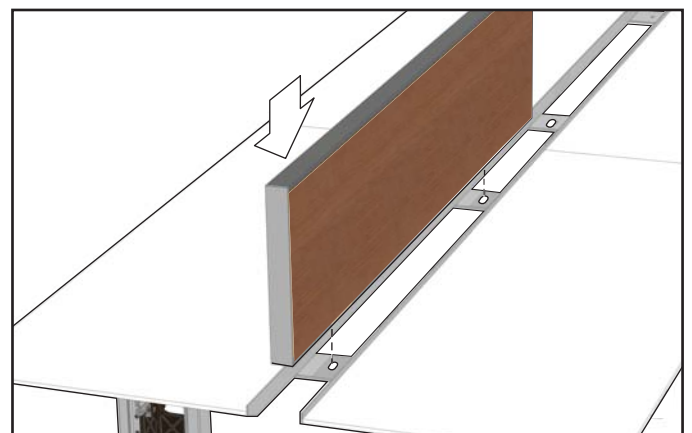

16

- Set divider between the tops and onto the table support brackets aligning threaded divider posts with slots in table support brackets.
- The bottom extrusion of the divider is notched to drop over the support bracket.

SECURING DIVIDER

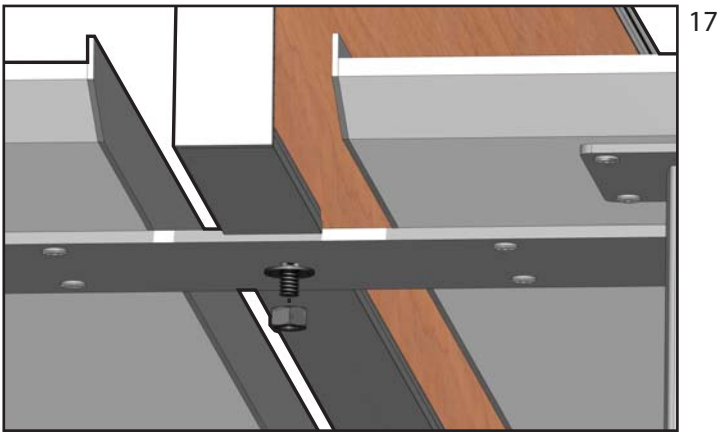

- Install the large washer onto the threaded rod.
- Tighten the 3/8" lock nut with a ratchet and appropriate socket .

ALIGNING DIVIDER WITH SPLINE

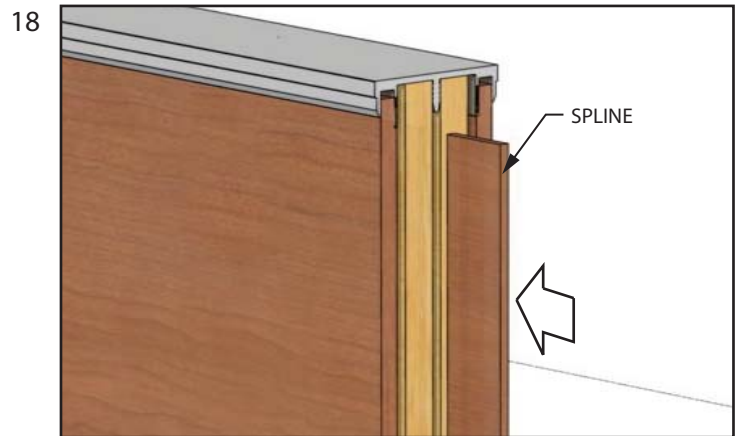

- Insert 1/8" thick wood spline into the machined groove at seam of the divider.

REMOVING GAPS

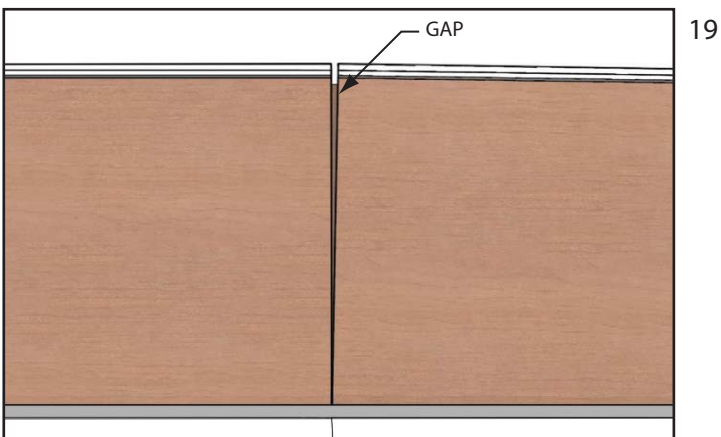

- The divider panels should have no gaps when mounted beside each other.
- If a gap appears only at the top of the divider raise the levelers at the ends of the table.
- If a gap appears only at the bottom of the divider raise the levelers in the middle of the table.

ATTACHING BASE TO RETURN



When returns are included

- Place the returns upside down on a clean surface.
 - Attach base to the return using 1" x 1/4 - 20 flat head hex socket bolt.
- The back of the base should be 6 3/4" from the edge of the table.

ATTACHING BASE TO TOP

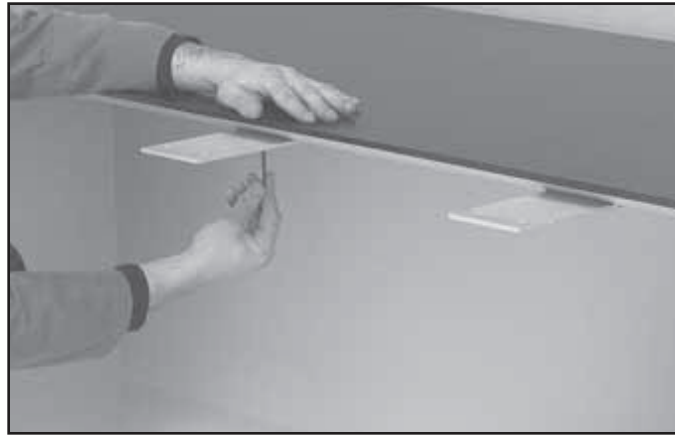

21

- Install 2 flat brackets to the underside of the main top with 1" x 1/4 - 20 flat head hex socket bolts. Threaded inserts are pre-installed in the top.

ATTACHING BRACKETS TO RETURN



22

- Place return top in position, align the threaded inserts with holes in the bracket and install 1" x 1/4 - 20 flat head hex socket bolt.

REPLACING BASE PANELS

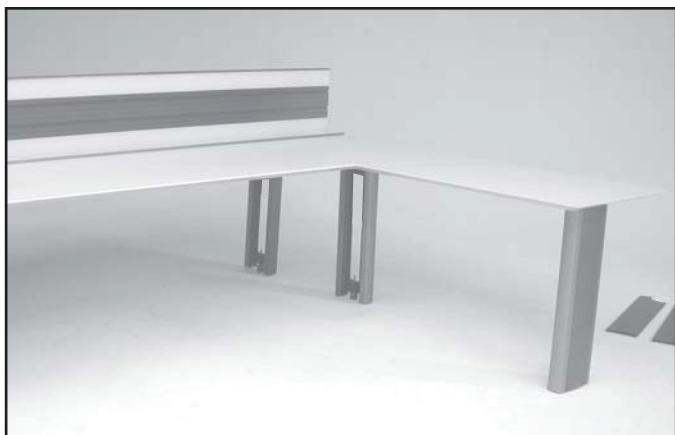

23

- Attach base covers to the bases. The exterior bases will not have any cutouts on the panels.
- The interior panels will receive one panel with a cutout on top right, and one panel with cutout in top left.