

Precedent Office- BIFMA Typical Private Office, example 1

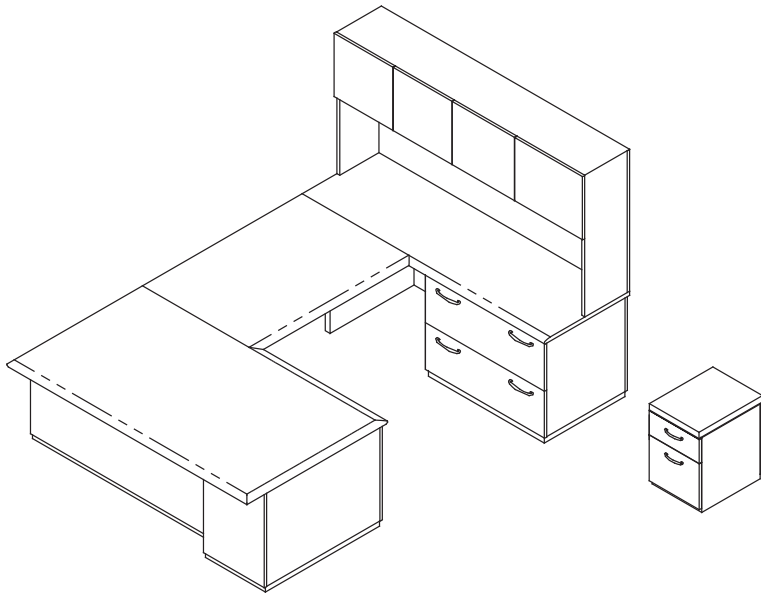

Isometric

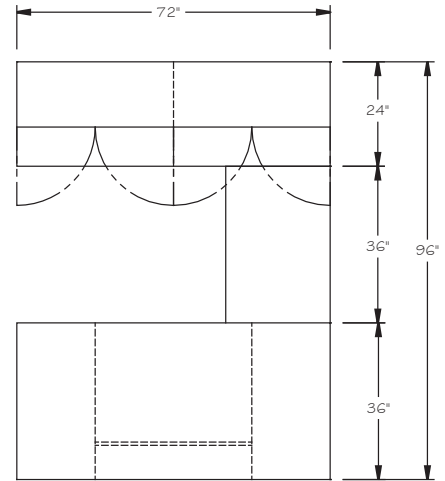

Plan View

Possible LEED credits – Commercial Interiors

Materials (extracted/harvested origin)												MR 4.1, 4.2	MR 6	MR 7	EQ 4.5	
	Total Weight	MDF (Alberta, Canada)	Particle board (Quebec, Canada)	Virgin Wood (source varies)	Plywood (Ontario, Canada)	Tentest	Fabric	Misc. Plastic	Glass	* Aluminum (Ontario, Canada)	Steel	Post consumer Recycled	Pre consumer Recycled	Rapidly Renewable	FSC Mixed Credit	Greenguard indoor Air Quality Certified
lbs	671.3	183.6	372.8	57.8	0	9.3	1.9	2.0	0	0	46.0	11.5	556.4	0	Value 100% of product cost Available on request	Pending Testing
%		27.3%	55.4%	8.6%	0%	1.4%	0.3%	0.3%	0%	0%	6.8%	1.7%	82.6%	0%		

Urea-Formaldehyde Free- MDF and Particle board are available on request.

Particle Board- Contains Urea-Formaldehyde resin. CARB phase 1 compliant.

MDF- Contains Polymerized Urea-Formaldehyde resin (CAS no. 9011-05-6) 6% - 12% by weight. CARB phase 1 compliant.

MR 2.1- Construction waste management, Nienkamper blanket wraps all furniture and uses cardboard boxes for hardware.

MR 5.1- Origin, Toronto, Ontario, Canada

MR 6 credit- Rapidly renewable materials are available and can be used on work surfaces (i.e. bamboo).

MR 7 credit- Nienkamper is FSC (Forest Stewardship Council) Chain of Custody (code # SW-COC-003521) and Controlled Wood (code # SW-CW-003521).

*Aluminum- Nienkamper only uses 100% Pre-consumer recycled aluminum extrusions. (Recycled in Ontario, Canada)

V09.08.09